

20A, 650V SUPER JUNCTION MOS POWER TRANSISTOR

DESCRIPTION

STS65R190F(L8A)(T)(S)(D)S2 is an N-channel enhancement mode high voltage power MOSFETs produced using Silan's super junction MOS technology. It achieves low conduction loss and switching losses. It leads the design engineers to their power converters with high efficiency, high power density, and superior thermal behavior. Furthermore, it's universal applicable, i.e., suitable for hard and soft switching topologies.

FEATURES

- ◆ 20A, 650V, $R_{DS(on)(typ.)}=0.155\Omega@V_{GS}=10V$
- ◆ New revolutionary high voltage technology
- ◆ Ultra low gate charge
- ◆ Periodic avalanche rated
- ◆ Extreme dv/dt rated
- ◆ High peak current capability
- ◆ 100% avalanche tested
- ◆ Pb-free lead plating
- ◆ RoHS compliant

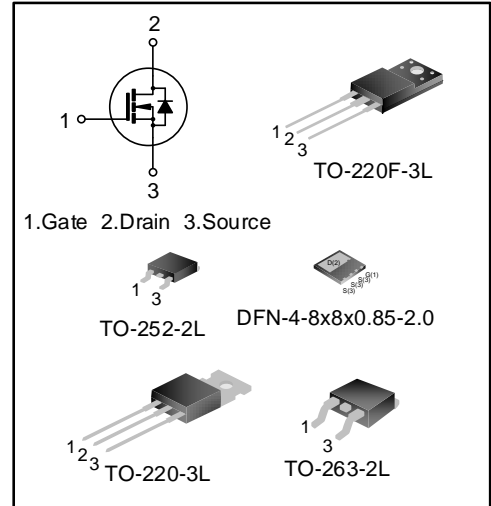

KEY PERFORMANCE PARAMETERS

Characteristics	Ratings	Unit
V_{DS}	650	V
$V_{GS(th)}$	2.5~4.5	V
$R_{DS(on),max.}$	0.19	Ω
$I_{D,pulse}$	80	A
$Q_g,typ.$	33	nC

ORDERING INFORMATION

Part No.	Package	Marking	Hazardous Substance Control	Packing Type
STS65R190FS2	TO-220F-3L	65R190FS2	Halogen free	Tube
STS65R190L8AS2TR	DFN-4-8x8x0.85-2.0	65R190S2	Halogen free	Tape & Reel
STS65R190TS2	TO-220-3L	65R190TS2	Halogen free	Tube
STS65R190SS2	TO-263-2L	65R190SS2	Halogen free	Tube
STS65R190SS2TR	TO-263-2L	65R190SS2	Halogen free	Tape & Reel
STS65R190DS2TR	TO-252-2L	65R190S2	Halogen free	Tape & Reel

ABSOLUTE MAXIMUM RATINGS (UNLESS OTHERWISE NOTED, $T_J=25^\circ\text{C}$)

Characteristics	Symbol	Test conditions	Ratings			Unit
			Min.	Typ.	Max.	
Drain-source Voltage	V_{DS}	--	--	--	650	V
Gate-source Voltage (Static)	V_{GS}	--	-30	--	30	V
Gate-source Voltage (Dynamic)	V_{GS}	AC ($f>1\text{Hz}$)	-30	--	30	V
Drain Current	I_D	$T_C=25^\circ\text{C}$	--	--	20	A
		$T_C=100^\circ\text{C}$	--	--	12	A
Drain Current Pulsed (Note 1)	I_{DM}	$T_C=25^\circ\text{C}$	--	--	80	A
Power Dissipation (TO-220F-3L) (Note 2)	P_D	$T_C=25^\circ\text{C}$	--	--	43	W
Power Dissipation (DFN-4-8x8x0.85-2.0) (Note 2)	P_D	$T_C=25^\circ\text{C}$	--	--	147	W
Power Dissipation (Note 2) (TO-220-3L) (TO-263-2L)	P_D	$T_C=25^\circ\text{C}$	--	--	169	W
Power Dissipation (TO-252-2L) (Note 2)	P_D	$T_C=25^\circ\text{C}$	--	--	139	W
Single Pulsed Avalanche Energy	E_{AS}	$L=79\text{mH}$, $V_{DD}=100\text{V}$, $R_G=25\Omega$, starting temperature $T_J=25^\circ\text{C}$	--	--	465	mJ
Single Pulsed Current	I_{AS}	--	--	--	3.2	A
Reverse Diode dv/dt	dv/dt	$V_{DS}=0\sim 400\text{V}$, $I_{SD}\leq I_S$, $T_J=25^\circ\text{C}$	--	--	50	V/ns
MOSFET dv/dt Ruggedness	dv/dt	$V_{DS}=0\sim 480\text{V}$	--	--	100	V/ns
Operation Junction Temperature Range	T_J	--	-55	--	150	$^\circ\text{C}$
Storage Temperature Range	T_{stg}	--	-55	--	150	$^\circ\text{C}$
Continuous Diode Forward Current	I_S	$T_C=25^\circ\text{C}$, integral reverse P-N junction diode in the MOSFET	--	--	20	A
Diode Pulse Current	$I_{S,pulse}$		--	--	80	A
Maximum Diode Commutation Speed	di/dt	$V_{DS}=0\sim 400\text{V}$, $I_{SD}\leq I_S$, $T_J=25^\circ\text{C}$	--	--	250	A/ μs

THERMAL CHARACTERISTICS

Table 1. TO-220F-3L (STS65R190FS2)

Characteristics	Symbol	Test conditions	Ratings			Unit
			Min.	Typ.	Max.	
Thermal Resistance, Junction-case, Bottom	$R_{\theta JC}$	--	--	--	2.9	°C/W
Thermal Resistance, Junction-ambient	$R_{\theta JA}$	--	--	--	62.5	°C/W
Soldering Temperature (in line)	T_{sold}	15_{-0}^{+2} sec, 1time	--	--	260	°C

Table 2. DFN-4-8x8x0.85-2.0 (STS65R190L8AS2)

Characteristics	Symbol	Test conditions	Ratings			Unit
			Min.	Typ.	Max.	
Thermal Resistance, Junction-case, Bottom	$R_{\theta JC}$	--	--	--	0.85	°C/W
Thermal Resistance, Junction-ambient	$R_{\theta JA}$	--	--	--	62.0	°C/W
Soldering Temperature (SMD)	T_{sold}	Reflow soldering: 10 ± 1 sec, 3times	--	--	260	°C

Table 3. TO-220-3L (STS65R190TS2)

Characteristics	Symbol	Test conditions	Ratings			Unit
			Min.	Typ.	Max.	
Thermal Resistance, Junction-case, Bottom	$R_{\theta JC}$	--	--	--	0.74	°C/W
Thermal Resistance, Junction-ambient	$R_{\theta JA}$	--	--	--	62.5	°C/W
Soldering Temperature (in line)	T_{sold}	15_{-0}^{+2} sec, 1time	--	--	260	°C

Table 4. TO-263-2L (STS65R190SS2)

Characteristics	Symbol	Test conditions	Ratings			Unit
			Min.	Typ.	Max.	
Thermal Resistance, Junction-case, Bottom	$R_{\theta JC}$	--	--	--	0.74	°C/W
Thermal Resistance, Junction-ambient	$R_{\theta JA}$	--	--	--	62.5	°C/W
Soldering Temperature (SMD)	T_{sold}	Reflow soldering: 10 ± 1 sec, 3times	--	--	260	°C

Table 5. TO-252-2L (STS65R190DS2)

Characteristics	Symbol	Test conditions	Ratings			Unit
			Min.	Typ.	Max.	
Thermal Resistance, Junction-case, Bottom	$R_{\theta JC}$	--	--	--	0.90	°C/W
Thermal Resistance, Junction-ambient	$R_{\theta JA}$	--	--	--	62.0	°C/W
Soldering Temperature (SMD)	T_{sold}	Reflow soldering:: 10 ± 1 sec, 3times	--	--	260	°C

ELECTRICAL CHARACTERISTICS (UNLESS OTHERWISE NOTED, $T_J=25^{\circ}\text{C}$)
Static characteristics

Characteristics	Symbol	Test conditions	Ratings			Unit
			Min.	Typ.	Max.	
Drain-source Breakdown Voltage	BV_{DSS}	$V_{GS}=0V, I_D=250\mu A$	650	--	--	V
Drain-source Leakage Current	I_{DSS}	$V_{DS}=650V, V_{GS}=0V, T_J=25^{\circ}\text{C}$	--	--	1.0	μA
		$V_{DS}=650V, V_{GS}=0V, T_J=125^{\circ}\text{C}$	--	2.0	--	
Gate-source Leakage Current	I_{GSS}	$V_{GS}=\pm 30V, V_{DS}=0V$	--	--	± 100	nA
Gate Threshold Voltage	$V_{GS(th)}$	$V_{GS}=V_{DS}, I_D=250\mu A$	2.5	--	4.5	V
Static Drain-source On State Resistance	$R_{DS(on)}$	$V_{GS}=10V, I_D=10A$	--	0.155	0.19	Ω
Gate Resistance	R_G	$f=1\text{MHz}$	--	2.4	--	Ω

Dynamic characteristics

Characteristics	Symbol	Test conditions	Ratings			Unit
			Min.	Typ.	Max.	
Input Capacitance	C_{iss}	$f=1\text{MHz}, V_{GS}=0V, V_{DS}=100V$	--	1540	--	pF
Output Capacitance	C_{oss}		--	55	--	
Reverse Transfer Capacitance	C_{rss}		--	1.7	--	
Turn-on Delay Time	$t_{d(on)}$	$V_{DD}=380V, V_{GS}=10V, R_G=25\Omega, I_D=20A$ (Notes 3, 4)	--	29	--	ns
Turn-on Rise Time	t_r		--	60	--	
Turn-off Delay Time	$t_{d(off)}$		--	76	--	
Turn-off Fall Time	t_f		--	47	--	
Total Gate Charge	Q_g	$V_{DD}=480V, V_{GS}=10V, I_D=20A$ (Notes 3, 4)	--	33	--	nC
Gate-source Charge	Q_{gs}		--	12	--	
Gate-drain Charge	Q_{gd}		--	12	--	
Gate-plateau Voltage	$V_{plateau}$		--	6.5	--	V

Reverse diode characteristics

Characteristics	Symbol	Test conditions	Ratings			Unit
			Min.	Typ.	Max.	
Diode Forward Voltage	V_{SD}	$I_S=20A, V_{GS}=0V$	--	--	1.4	V
Reverse Recovery Time	T_{rr}	$I_S=5.0A, V_{GS}=0V, di_F/dt=100A/\mu s$ (Note 3)	--	193	--	ns
Reverse Recovery Charge	Q_{rr}		--	1.7	--	μC
Reverse Recovery Peak Current	I_{rrm}		--	23	--	A

Notes:

- Pulse time $5\mu s$;
- The dissipation power will change with temperature, derating above 25°C :
 $0.34W/^{\circ}\text{C}$ (TO-220F-3L) / $1.18W/^{\circ}\text{C}$ (DFN-4-8x8x0.85-2.0) / $1.35W/^{\circ}\text{C}$ (TO-220-3L)(TO-263-2L) / $1.11W/^{\circ}\text{C}$ (TO-252-2L);
- Pulse Test: Pulse width $\leq 300\mu s$, Duty cycle $\leq 2\%$;
- Essentially independent of operating temperature.

TYPICAL CHARACTERISTICS

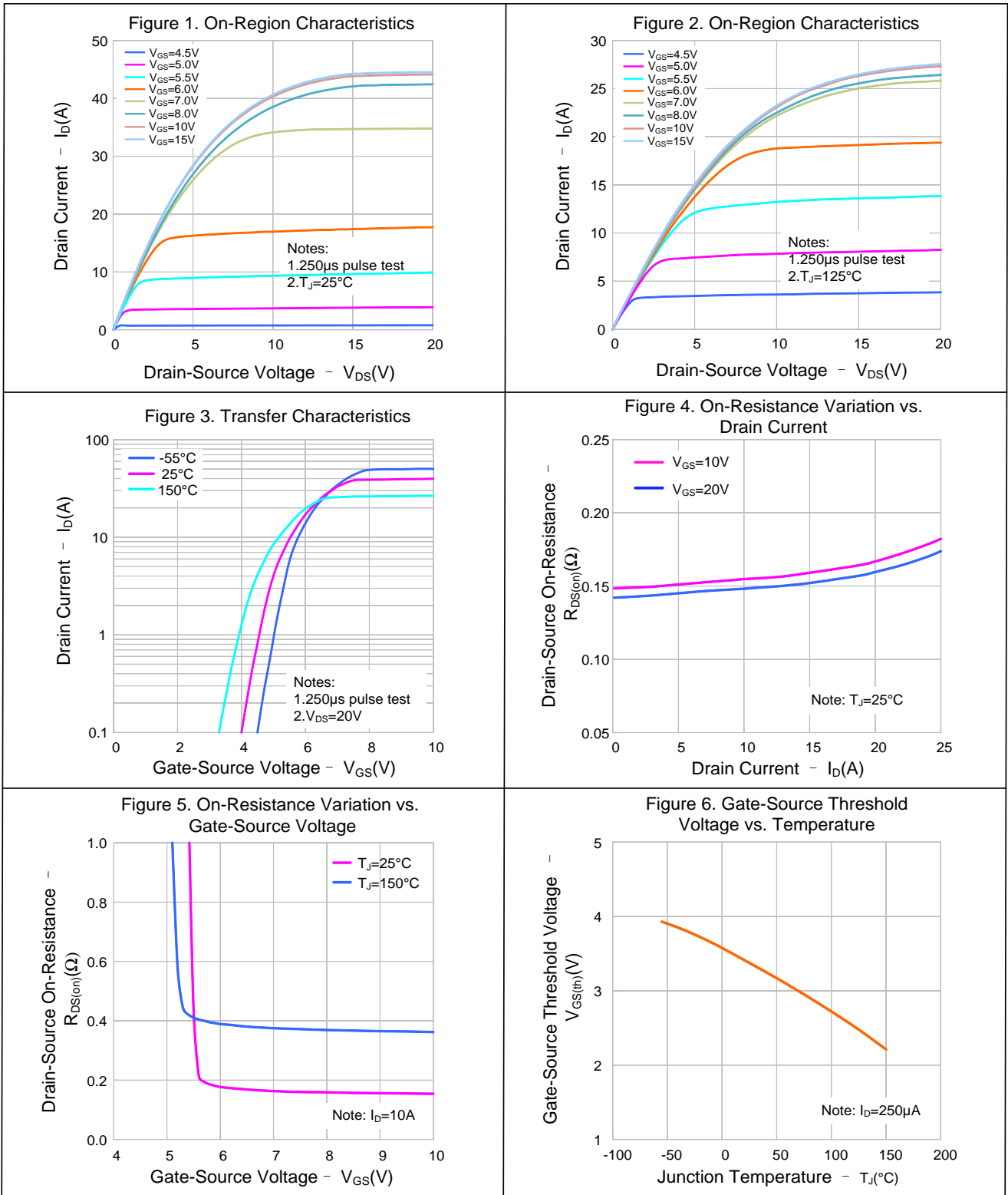

TYPICAL CHARACTERISTICS (CONTINUED)

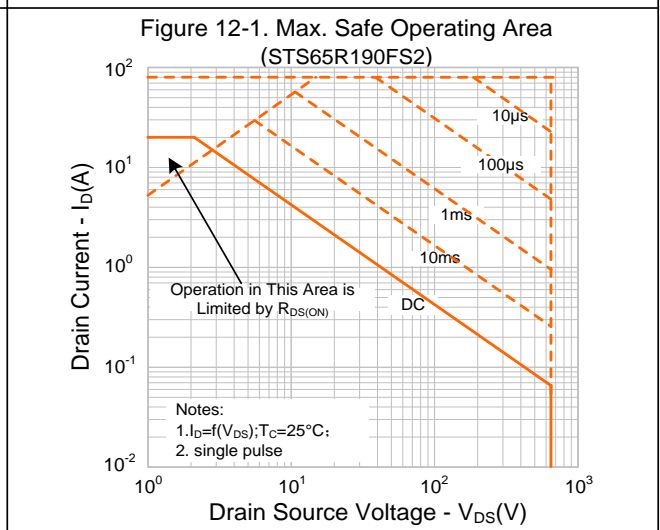
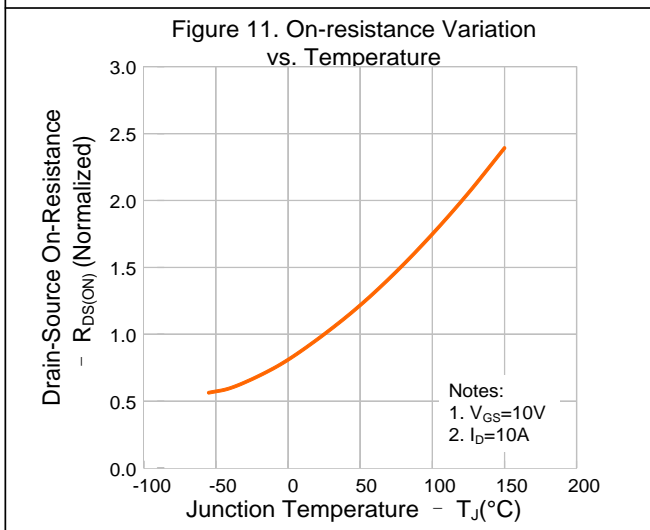
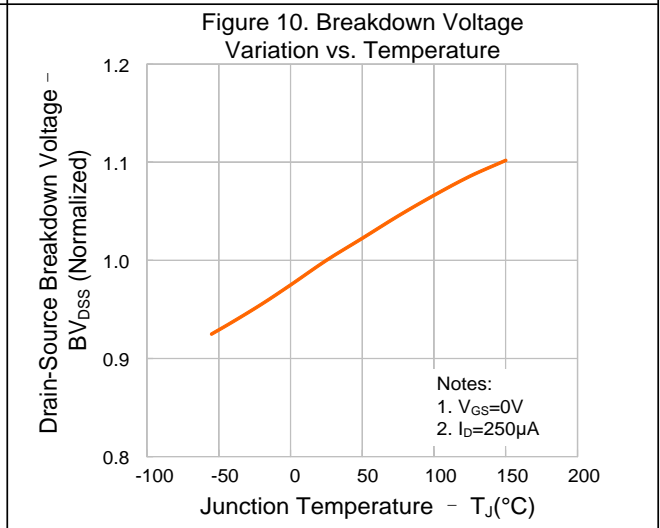
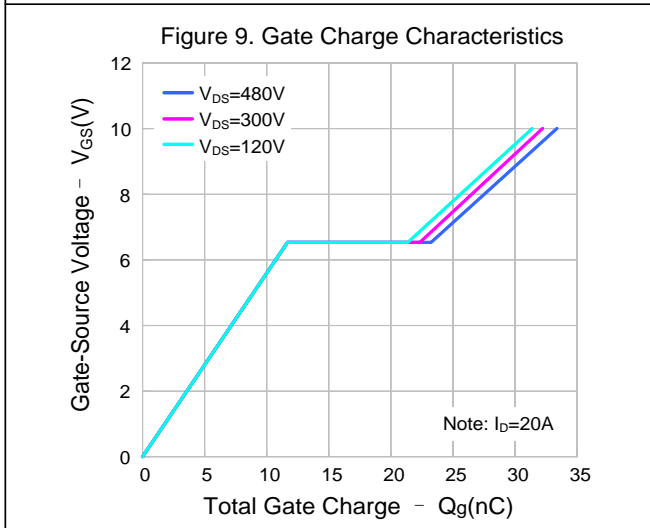
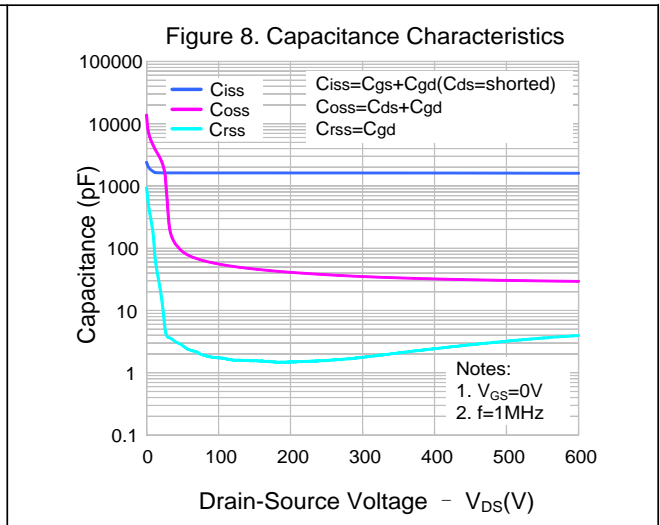
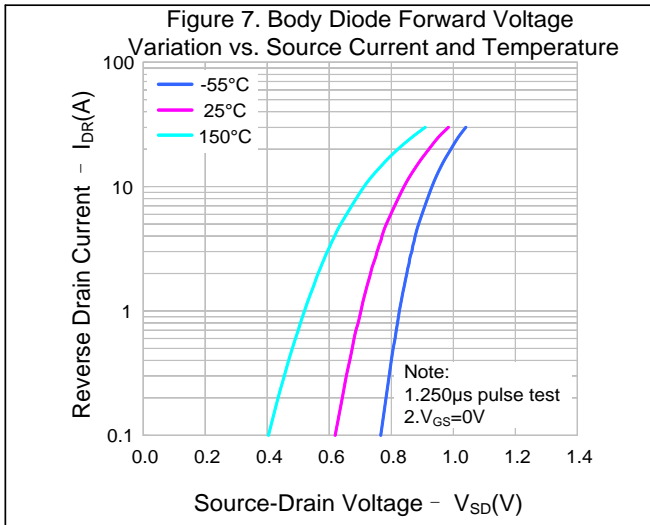

TYPICAL CHARACTERISTICS (CONTINUED)

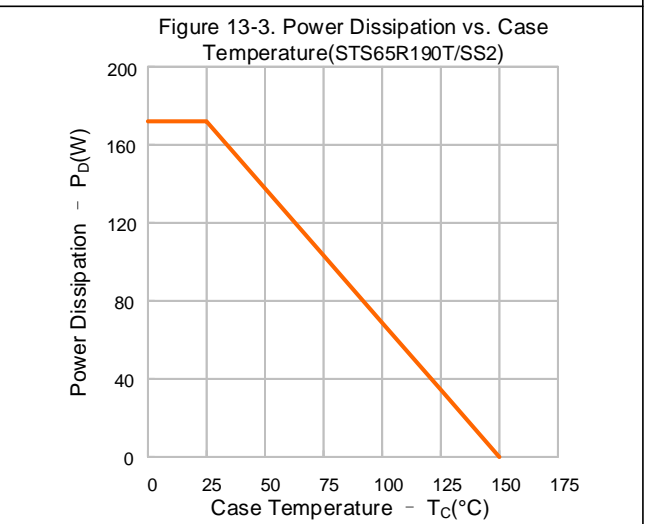
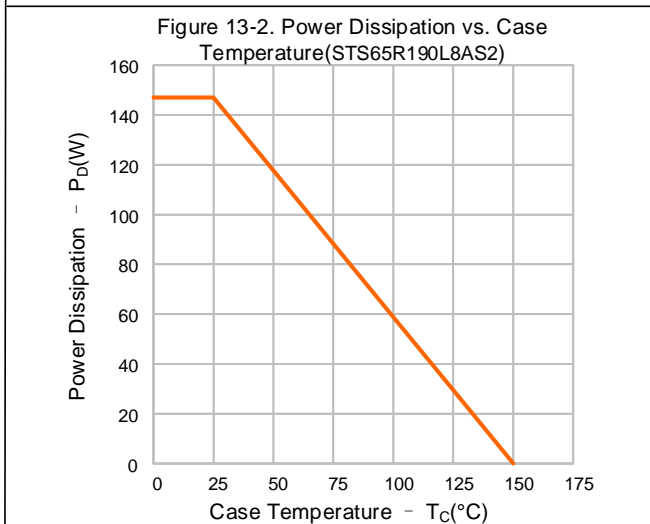
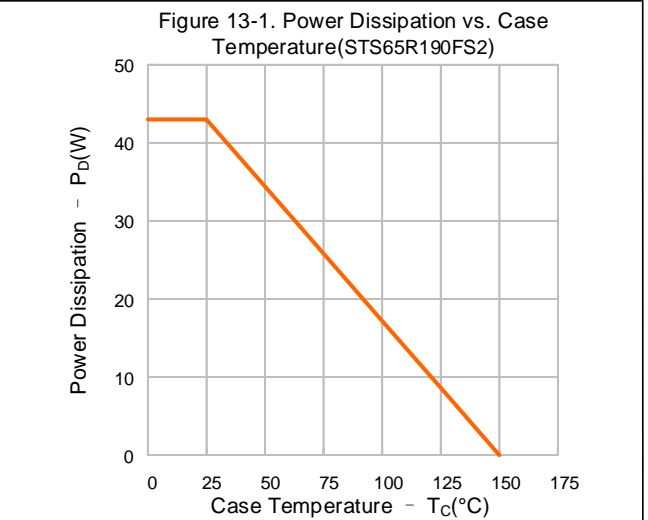
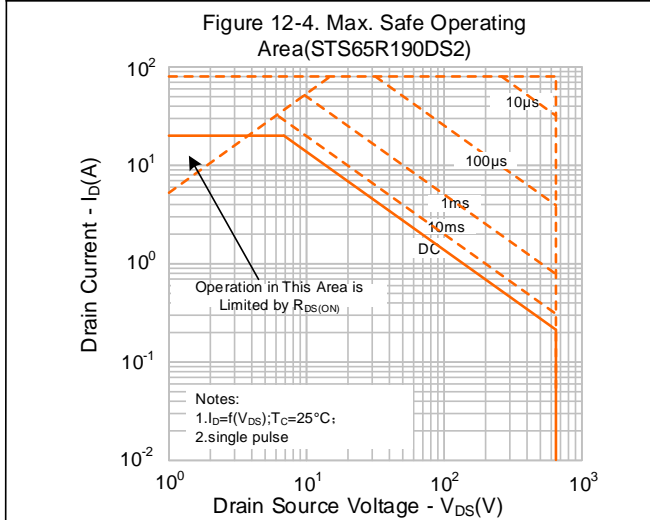
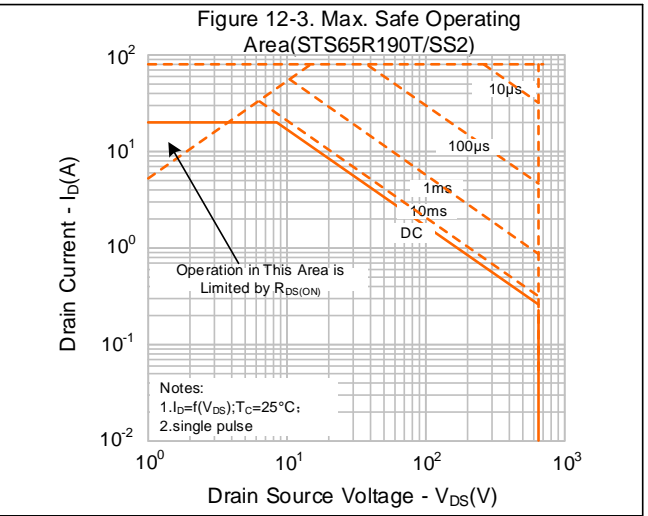
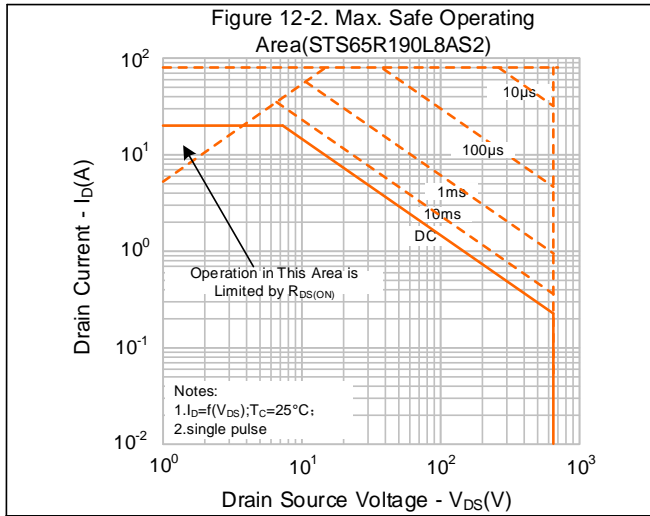



TYPICAL CHARACTERISTICS (CONTINUED)

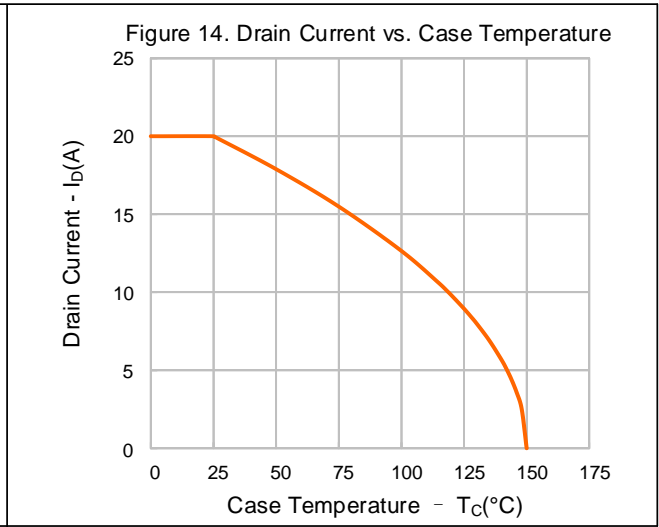
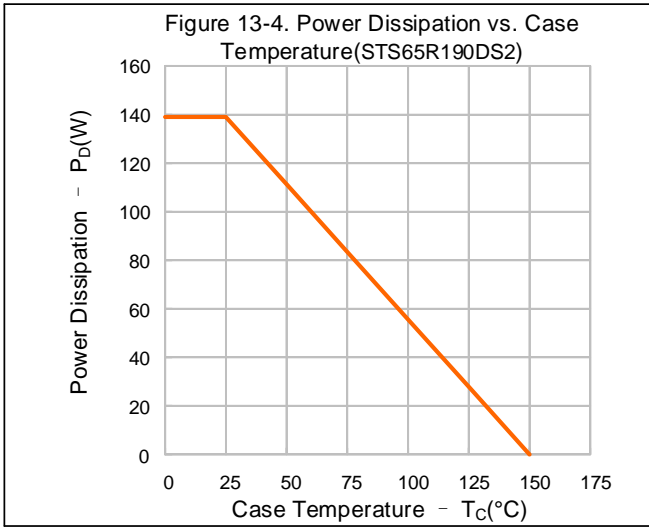

TYPICAL TEST CIRCUIT

Gate Charge Test Circuit & Waveform

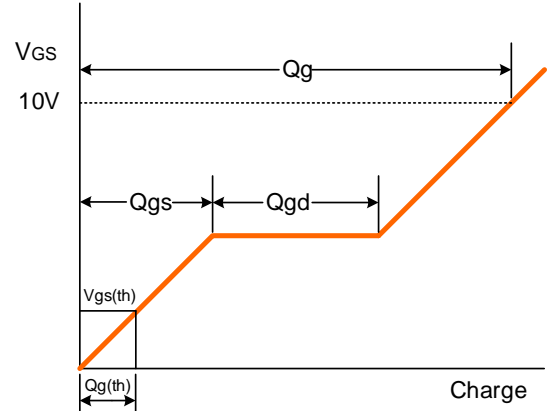
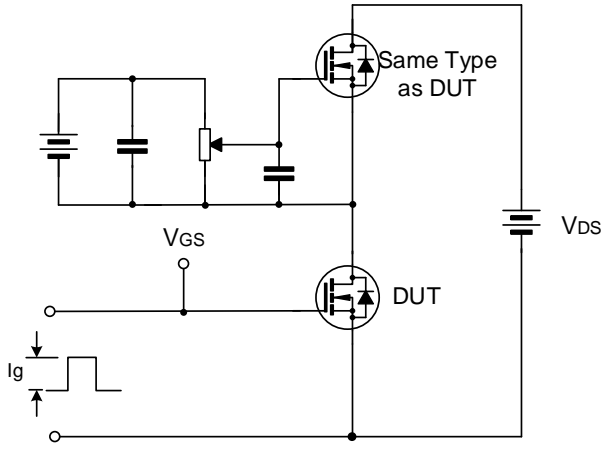

Resistive Switching Test Circuit & Waveform

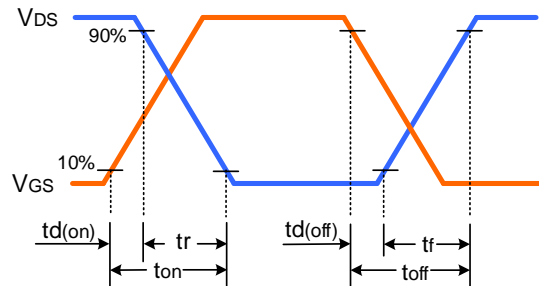
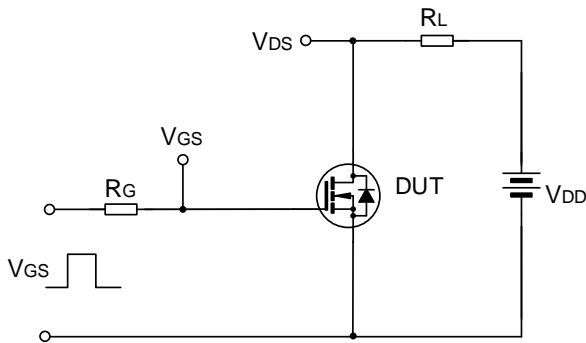

Unclamped Inductive Switching Test Circuit & Waveform

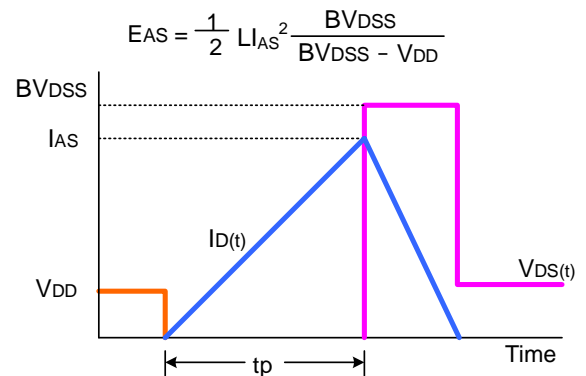
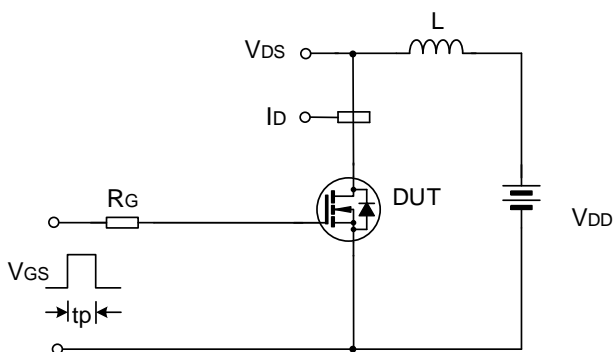

PACKAGE OUTLINE

TO-220F-3L

UNIT: mm

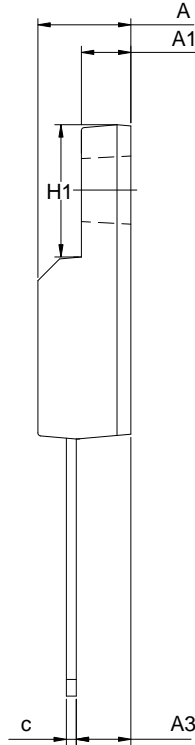
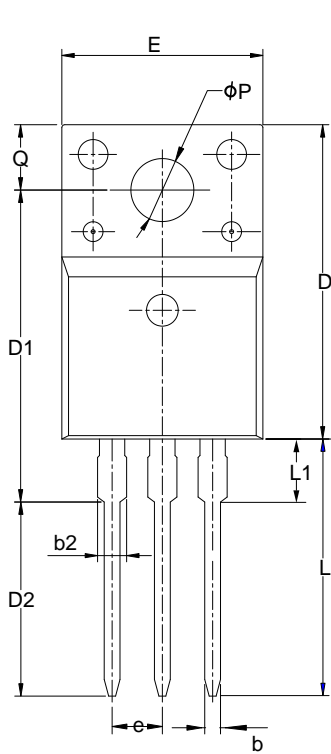

SYMBOL	MILLIMETER		
	MIN	NOM	MAX
A	4.42	4.70	5.02
A1	2.30	2.54	2.80
A3	2.50	2.76	3.10
b	0.70	0.80	0.90
b2	—	—	1.47
c	0.35	0.50	0.65
D	15.25	15.87	16.25
D1	15.30	15.75	16.30
D2	9.30	9.80	10.30
E	9.73	10.16	10.36
e	2.54BSC		
H1	6.40	6.68	7.00
L	12.48	12.98	13.48
L1	—	—	3.50
ϕP	3.00	3.18	3.40
Q	3.05	3.30	3.55

DFN-4-8x8x0.85-2.0

UNIT: mm

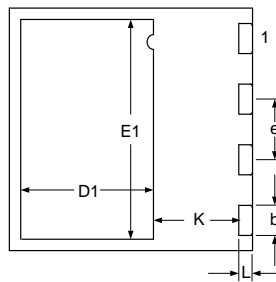
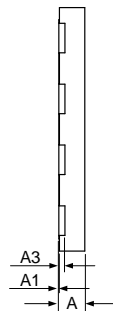
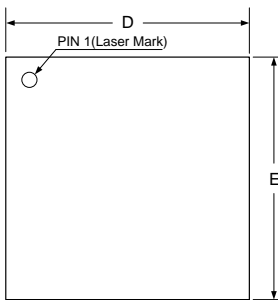

Top View

Side View

Bottom View



Side View

SYMBOL	MILLIMETER		
	MIN	NOM	MAX
A	0.80	0.85	0.90
A1	0.00	0.02	0.05
A3	0.20 REF		
b	0.90	1.00	1.10
D	7.90	8.00	8.10
D1	4.25	4.35	4.45
E	7.90	8.00	8.10
E1	7.10	7.20	7.30
e	1.90	2.00	2.10
K	2.65	2.75	2.85
L	0.40	0.50	0.60

PACKAGE OUTLINE (CONTINUED)

TO-220-3L

UNIT: mm

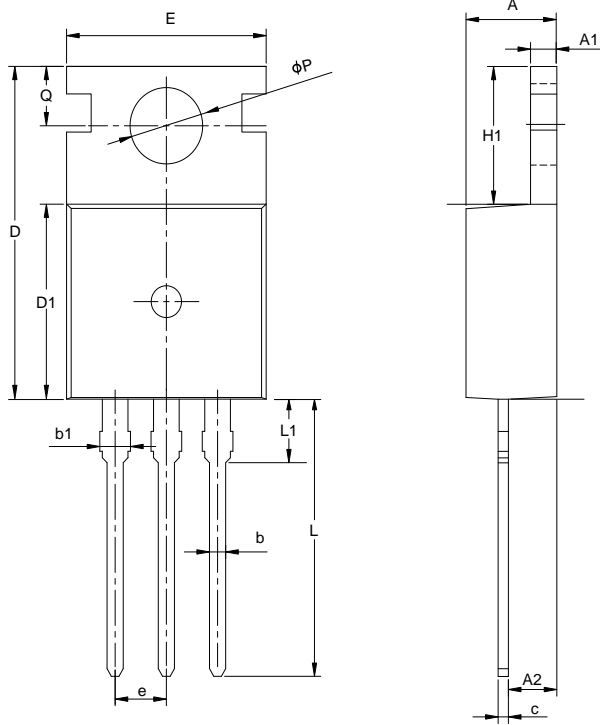

SYMBOL	MILLIMETER		
	MIN	NOM	MAX
A	4.30	4.50	4.70
A1	1.00	1.30	1.50
A2	1.80	2.40	2.80
b	0.60	0.80	1.00
b1	1.00	—	1.60
c	0.30	—	0.70
D	15.10	15.70	16.10
D1	8.10	9.20	10.00
E	9.60	9.90	10.40
e	2.54BSC		
H1	6.10	6.50	7.00
L	12.60	13.08	13.60
L1	—	—	3.95
ϕP	3.40	3.70	3.90
Q	2.60	—	3.20

TO-263-2L

UNIT: mm

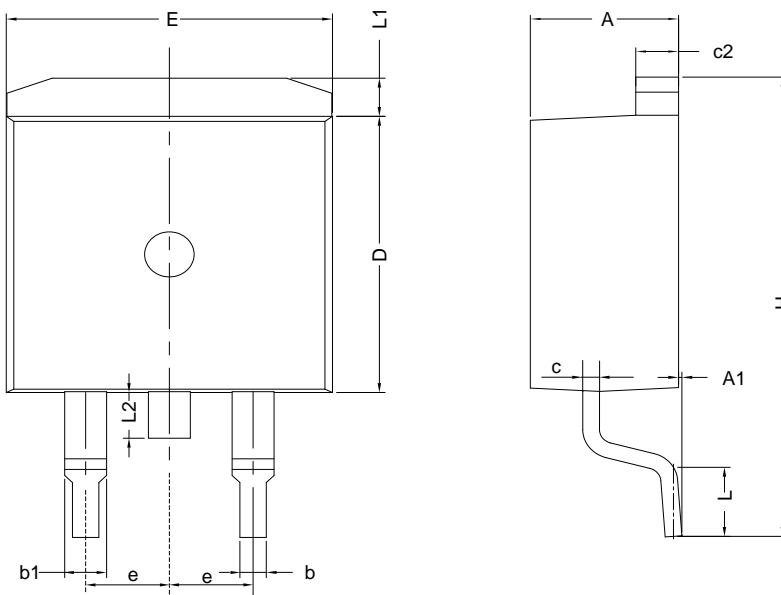

SYMBOL	MILLIMETER		
	MIN	NOM	MAX
A	4.30	4.57	4.72
A1	0	0.10	0.25
b	0.71	0.81	0.91
b1	1.17	—	1.50
c	0.30	—	0.60
c2	1.17	1.27	1.37
D	8.50	—	9.35
E	9.80	—	10.45
e	2.54BSC		
H	14.70	—	15.75
L	2.00	2.30	2.74
L1	1.12	1.27	1.42
L2	—	—	1.75

PACKAGE OUTLINE (CONTINUED)

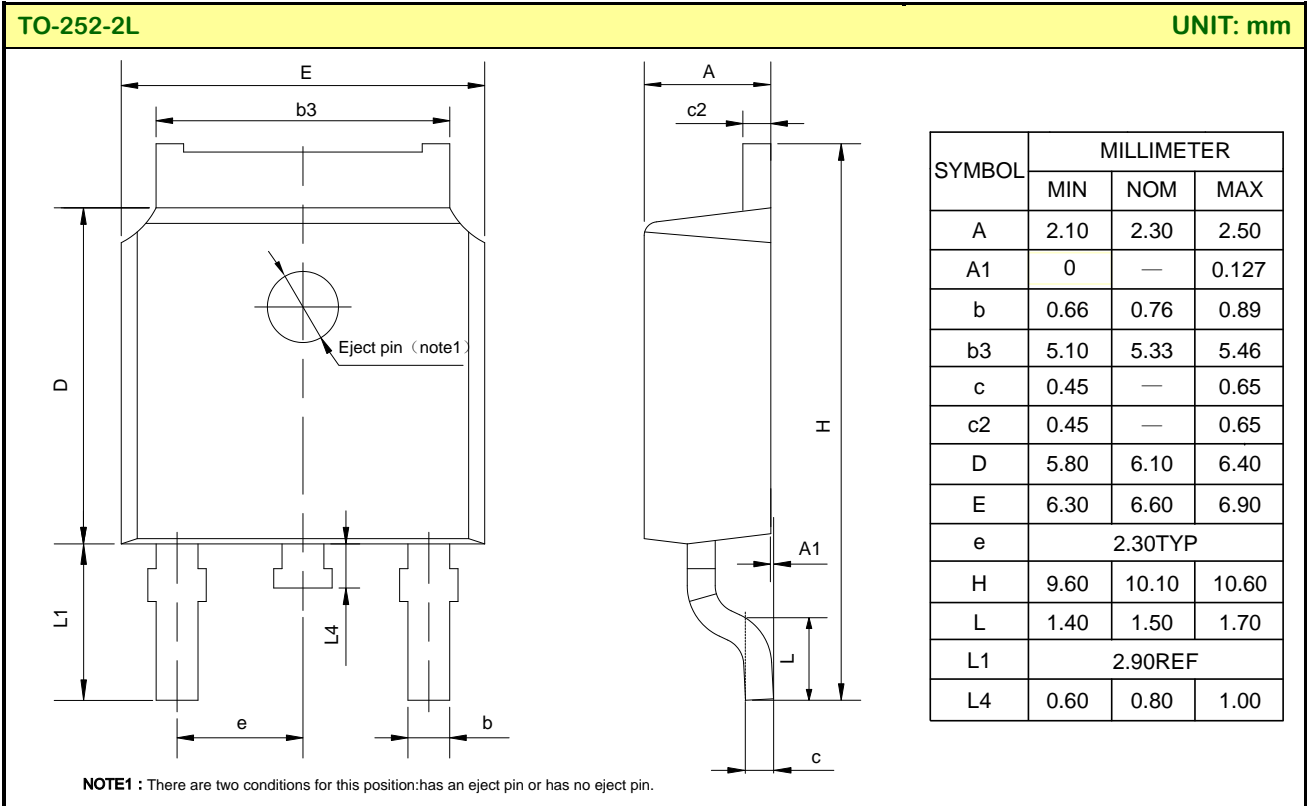

MOS DEVICES OPERATE NOTES:

Electrostatic charges may exist in many things. Please take following preventive measures to prevent effectively the MOS electric circuit as a result of the damage which is caused by discharge:

- The operator must put on wrist strap which should be earthed to against electrostatic.
- Equipment cases should be earthed.
- All tools used during assembly, including soldering tools and solder baths, must be earthed.
- MOS devices should be packed in antistatic/conductive containers for transportation.

Important notice :

1. Silan reserves the right to make changes of this instruction without notice.
2. Customers should obtain the latest relevant information when purchasing and should verify whether such information is latest and complete. Please read this instruction and application manual and related materials carefully before using products, including the circuit operation precautions, etc.
3. The products belong to consumer electronic products. Silan does not give any warranties as to the suitability of the Silan's product for any specific use. The design intent, design definition and design of the product are not intended for application (the application stated in this instruction includes use, etc.) in transportation equipment, medical equipment, life-saving equipment, aerospace equipment, , non-civil equipment or non-civil use, etc. (the equipment stated in this instruction includes systems, devices, etc., all referred to as equipment).The product should not be used in any equipment or system whose manufacture, use or sale is prohibited under any applicable laws or regulations ("unintended use"). If the product is used for unintended use, therefore the full risks of such products application are borne by the customer and Silan assumes no liability for the product used for the unintended use. If the customer intends to use the Silan's product in a application where malfunction or failure can be reasonably be expected to result in personal injury, or serious property, or environment damage, the customer shall make adequate assessment, testing and verification, and Silan shall not be liable for such applications.
4. The application of the product described in this instruction, the application manual of the product and related materials is for illustrative purposes only, and Silan makes no warranty that such application can be used directly without further testing, verification or modification. Silan is not responsible for any assistance in product application or customers' product design. Customer shall be responsible for the application of Silan's products and the design, manufacture and use of customers' products using Silan's products (in this document, "use products", "apply Silan's products", "product application" and "customers' products using Silan's products" are synonymous). It is the sole responsibility of the customer to take the following actions: 1) Verify and determine whether Silan's products are suitable for the customers' applications and customers' products; 2) All applicable standards of the customers' industry shall be complied with and fully tested and verified when applying Silan's product or using Silan's product to develop and design customers' products; 3) Although Silan is constantly committed to improve product's quality and reliability, semiconductor products have possibility to malfunction or fail in various application environments. Customers are responsible for complying with safety standards and for providing adequate designs and safeguards for customers' products using Silan's product to minimize risks and avoid situations in which a malfunction or failure could cause bodily injury or damage to property; 4) When using the products, please do not exceed the maximum rating of the products, Stress above one or more limiting values will cause damage to the product and the equipment or affect the reliability to the equipment (customers' product); 5) Ensure customers' product using Silan's product are designed, manufactured and used in full compliance with all applicable standards, safety standards and other requirements of the customers' industry. The parameters stated in this instruction may and do vary in different applications, actual performance may vary over time. Customers must use the products within their effective static storage period, please contact Silan sales or Silan customer service support and sales management department if there is any questions about the effective static storage period, Silan does not assume any responsibility if the product has exceeded the static storage period when it is used.
5. Do not disassemble, reverse-engineer, alter, modify, decompile or copy product, without Silan's prior written consent.
6. Please identify Silan's trademark when purchasing our product. Please contact us if there is any question. Our products are not sold through TAOBAO or any other third-party e-commerce platforms. If customers purchase from such platforms, please contact us in writing before purchasing to confirm whether the product is authentic and original from Silan.
7. Please use and apply product in compliance with all applicable laws and regulations, including but not limited to trade control regulations etc. The product is civil electronic product, please do not use it in non-civil fields.
8. Product promotion is endless, our company will wholeheartedly provide customers with better products!
9. Website: <http://www.silan.com.cn>



Part No.: STS65R190F(L8A)(T)(S)(D)S2 Document Type: Datasheet
Copyright: HANGZHOU SILAN MICROELECTRONICS CO.,LTD Website: <http://www.silan.com.cn>

Rev.: 1.3

Revision History:

1. Add TO-252-2L package
 2. Update typical characteristics curve
-

Rev.: 1.2

Revision History:

1. Add STS65R190SS2(TO-263-2L) package
 2. Update typical characteristics curve
 3. Update important notice
-

Rev.: 1.1

Revision History:

1. Add STS65R190TS2(TO-220-3L) package
 2. Add curve 12-3、13-3
-

Rev.: 1.0

Revision History:

1. First release
-